

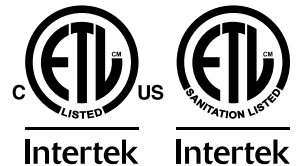

**Pasta Cookers**  
Models CE-CN-0011-NG, 0022-NG  
Items 47714, 48000  
**Instruction Manual**



*Revised - 02/01/2024*



Toll Free: 1-800-465-0234  
Fax: 905-607-0234  
Email: [service@omcan.com](mailto:service@omcan.com)  
[www.omcan.com](http://www.omcan.com)



# ***Table of Contents***

Model CE-CN-0011-NG / Model CE-CN-0022-NG

---

<b>Section</b>	<b>Page</b>
General Information -----	3 - 4
Safety and Warranty -----	4 - 6
Technical Specifications -----	6
Installation -----	6 - 8
Operation -----	8 - 9
Maintenance -----	10
Troubleshooting -----	11 - 12
Parts Breakdown -----	13 - 16
Notes -----	17 - 18
Warranty Registration -----	19



# General Information

---

Omcan Manufacturing and Distributing Company Inc., Food Machinery of America, Inc. dba Omcan and Omcan Inc. are not responsible for any harm or injury caused due to any person's improper or negligent use of this equipment. The product shall only be operated by someone over the age of 18, of sound mind, and not under the influence of any drugs or alcohol, who has been trained in the correct operation of this machine, and is wearing authorized, proper safety clothing. Any modification to the machine voids any warranty, and may cause harm to individuals using the machine or in the vicinity of the machine while in operation.

## CHECK PACKAGE UPON ARRIVAL

Upon receipt of an Omcan shipment please inspect for external damage. If no damage is evident on the external packaging, open carton to ensure all ordered items are within the box, and there is no concealed damage to the machine. If the package has suffered rough handling, bumps or damage (visible or concealed), please note it on the bill of lading before accepting the delivery and contact Omcan within 24 hours, so we may initiate a claim with the carrier. A detailed report on the extent of the damage caused to the machine must be filled out within three days, from the delivery date shown in the shipping documents. Omcan has no recourse for damaged products that were shipped collect or third party.

**Before operating any equipment, always read and familiarize yourself with all operation and safety instructions.**

Omcan would like to thank you for purchasing this machine. It's of the utmost importance to save these instructions for future reference. Also save the original box and packaging for shipping the equipment if servicing or returning of the machine is required.

---

Omcan Fabrication et distribution Compañie Limité et Food Machinery d'Amérique, dba Omcan et Omcan Inc. ne sont pas responsables de tout dommage ou blessure causé du fait que toute personne ait utilisé cet équipement de façon irrégulière. Le produit ne doit être exploité que par quelqu'un de plus de 18 ans, saine d'esprit, et pas sous l'influence d'une drogue ou d'alcool, qui a été formé pour utiliser cette machine correctement, et est vêtu de vêtements de sécurité approprié. Toute modification de la machine annule toute garantie, et peut causer un préjudice à des personnes utilisant la machine ou des personnes à proximité de la machine pendant son fonctionnement.

## VÉRIFIEZ LE COLIS DÈS RÉCEPTION

Dès réception d'une expédition d'Omcan veuillez inspecter pour dommages externes. Si aucun dommage n'est visible sur l'emballage externe, ouvrez le carton afin de s'assurer que tous les éléments commandés sont dans la boîte, et il n'y a aucun dommage dissimulé à la machine. Si le colis n'a subi aucune mauvaises manipulations, de bosses ou de dommages (visible ou cachée), notez-le sur le bond de livraison avant d'accepter la livraison et contactez Omcan dans les 24 heures qui suivent, pour que nous puissions engager une réclamation auprès du transporteur. Un rapport détaillé sur l'étendue des dommages causés à la machine doit être rempli dans un délai de trois jours, à compter de la date de livraison indiquée dans les documents d'expédition. Omcan n'a aucun droit de recours pour les produits endommagés qui ont été expédiés ou cueilli par un tiers transporteur.

# ***General Information***

---

**Avant d'utiliser n'importe quel équipement, toujours lire et vous familiariser avec toutes les opérations et les consignes de sécurité.**

**Omcan voudrais vous remercier d'avoir choisi cette machine. Il est primordial de conserver ces instructions pour une référence ultérieure. Également conservez la boîte originale et l'emballage pour l'expédition de l'équipement si l'entretien ou le retour de la machine est nécessaire.**

-----  
**Omcan Empresa De Fabricacion Y Distribucion Inc. Y Maquinaria De Alimentos De America, Inc. dba Omcan y Omcan Inc. no son responsables de ningun daño o perjuicio causado por cualquier persona inadecuada o el uso descuidado de este equipo. El producto solo podra ser operado por una persona mayor de 18 años, en su sano juicio y no bajo alguna influencia de droga o alcohol, y que este ha sido entrenado en el correcto funcionamiento de esta máquina, y ésta usando ropa apropiada y autorizada. Cualquier modificación a la máquina anula la garantía y puede causar daños a las personas usando la máquina mientras esta en el funcionamiento.**

## **REVISE EL PAQUETE A SU LLEGADA**

Tras la recepcion de un envio Omcan favor inspeccionar daños externos. Si no hay daños evidentes en el empaque exterior, Habra el carton para asegurarse que todos los articulos solicitados estén dentro de la caja y no encuentre daños ocultos en la máquina. Si el paquete ha sufrido un manejo de poco cuidado, golpes o daños (visible o oculto) por favor anote en la factura antes de aceptar la entrega y contacte Omcan dentro de las 24 horas, de modo que podamos iniciar una reclamación con la compañía. Un informe detallado sobre los daños causados a la máquina debe ser llenado en el plazo de tres días, desde la fecha de entrega que se muestra en los documentos de envío. Omcan no tiene ningun recurso por productos dañados que se enviaron a recoger por terceros.

**Antes de utilizar cualquier equipo, siempre lea y familiarizarse con todas las instrucciones de funcionamiento y seguridad.**

**Omcan le gustaría darle las gracias por la compra de esta máquina. Es de la mayor importancia para salvar estas instrucciones para futuras consultas. Además, guarda la caja original y el embalaje para el envío del equipo si servicio técnico o devolución de la máquina que se requiere.**

# ***Safety and Warranty***

---

**Note: post this manual in a prominent location for easy access. Please keep this manual for future reference.**

## **GENERAL INFORMATION**

Before attempting to operate your unit, read the instructions in this manual thoroughly.



# Safety and Warranty

---

**WARNING:** contain information about actions or conditions that may cause or result in a malfunction of your system.

The gas noodle cooker is designed for boiling pasta, noodles, vegetable etc. This cooker uses a millivolt temperature control circuit, which requires no external power. This model adopts an open-tank design with no tubes, which makes cleaning the water tank quick and easy. The noodle cooker requires installation of legs or optional casters at point of use. All noodle cookers are shipped with a package of standard accessories. Each noodle cooker is adjusted, tested, and inspected at the factory before crating for shipment. Water tanks are constructed of welded, heavy-gauge stainless steel. Heat is supplied by two stainless steel burners, which are installed under the tank bottom. A drain is installed at the right hand of the water tank, with a front-controlled manual ball valve. Each noodle cooker is equipped with a thermostat for precise temperature control. The thermostat is located at the front part of the water tank for rapid response to changes in loads and to provide the most accurate temperature measurement. A high temperature thermostat (hi-limit) shuts off gas to the burner assembly if the controlling thermostat fails. This unit was carefully inspected and packed before leaving the factory. The transportation company assumes full responsibility for safe delivery upon acceptance of the equipment for transport.

What to do if your equipment arrives damaged:

1. File a claim for damages immediately, regardless of the extent of damages.
2. Inspect for and record all visible loss or damage, and ensure that this information is noted on the freight bill or express receipt and is signed by the person making the delivery.

**RESIDENTIAL USERS:** vendor assumes no liability for parts or labor coverage for component failure or other damages resulting from installation in non-commercial or residential applications. The right is reserved to deny shipment for residential usage; if this occurs, you will be notified as soon as possible.

## 1 YEAR PARTS AND LABOUR WARRANTY

Within the warranty period, contact Omcan Inc. at 1-800-465-0234 to schedule an Omcan authorized service technician to repair the equipment locally.

Unauthorized maintenance will void the warranty. Warranty covers electrical and part failures, not improper use.

Please see <https://omcan.com/disclaimer> for complete info.

### WARNING:

The packaging components are classified as normal solid urban waste and can therefore be disposed of without difficulty.

In any case, for suitable recycling, we suggest disposing of the products separately (differentiated waste) according to the current norms.

# Safety and Warranty

---

DO NOT DISCARD ANY PACKAGING MATERIALS IN THE ENVIRONMENT!

# Technical Specifications

---

Model	CE-CN-0011-NG	CE-CN-0022-NG
Capacity	41.6 L / 11 Gal	83.3 L / 22 Gal
Number of Baskets	6	12
Temperature Range	50 - 125°C / 122 - 257°F	
Gas Type	Natural Gas	
Total BTU/h	70,000	140,000
Net Dimensions	35.4" x 15.7" x 46.8" 900 x 398 x 1189mm	35.4" x 31.4" x 46.9" 900 x 798 x 1190mm
Packaging Dimensions	19" x 38" x 36" / 483 x 965 x 914mm	38" x 43" x 39" / 965 x 1092 x 991mm
Net Weight	172 lbs. / 78 kgs.	363 lbs. / 164.7 kgs.
Packaging Weight	190 lbs. / 86.2 kgs.	402 lbs. / 182.3 kgs.
Item Number	47714	48000

# Installation

---

PROPER INSTALLATION IN ACCORDANCE WITH THE INSTRUCTIONS THAT FOLLOW IS ESSENTIAL FOR EFFICIENT, TROUBLE-FREE OPERATION OF YOUR NOODLE COOKER. ANY UNAUTHORIZED ALTERATIONS MADE TO THIS EQUIPMENT WILL VOID THE WARRANTY.

Upon arrival, inspect the cooker carefully for visible or concealed damage.

## CLEARANCE AND VENTILATION

The cooker(s) must be installed with a 6" (150mm) clearance at both sides and back when installed adjacent to combustible construction; no clearance is required when installed adjacent to noncombustible construction. A minimum of 24" (600 mm) clearance should be provided at the front of the cooker. One of the most important considerations of efficient cooker operation is ventilation. Make sure the cooker is installed to efficiently remove combustion by-products, and the kitchen ventilation system does not produce drafts that interfere with proper burner operation. The cooker flue opening must not be placed close to the intake of the exhaust fan, and the cooker must never have its flue extended in a "chimney" fashion. An extended flue will change the combustion characteristics of the cooker, causing longer recovery time. It also frequently causes delayed ignition. To provide the air flow necessary for good combustion and burner operation, the areas surrounding the noodle

cooker front, sides, and rear must be kept clear and unobstructed. Cooker must be installed in an area with an adequate air supply and adequate ventilation. Adequate distances must be maintained from the flue outlet of the cooker to the lower edge of the ventilation filter bank.

## NATIONAL CODE REQUIREMENTS

The type of gas for which the cooker is equipped is marked on the data plate attached to the inside of the cooker door. Connect a cooker marked “NAT” only to natural gas, those marked “PRO” only to propane gas. When installing this equipment in the UNITED STATES, the installation must conform to the latest edition of the National Fuel Gas Code, ANSI Z223.1. In CANADA, installation must conform to the latest edition of Standard CAN-/ GCA-B149.1 or .2, “Installation Codes for Gas Burning Appliances & Equipment”. In addition to the applicable national code or standard, installation must also be in accordance with any local codes for the area in which the equipment is installed. Installation shall be made with a gas connector that complies with national and local codes. In the UNITED STATES, the applicable code is ANSI Z21.69 with Addenda, “Standard for Connectors for Movable Gas Appliances”. Quick-Disconnect devices, if used, shall likewise comply with national and local codes. In the UNITED STATES, the code is ANSI Z21.41, “Standard for Quick-Disconnect Devices for Use with Gas Fuel”.

## PRE-CONNECTION PREPARATIONS

After the cooker has been positioned under the cook station exhaust hood, ensure the following has been accomplished:

1. Adequate means must be provided to limit the movement of cookers without depending upon the gas line connections. If a flexible gas hose is used, a restraining cable must be connected at all times when the cooker is in use. The restraining cable and installation instructions are packed with the flexible hose in the accessories box that was shipped with your unit.
2. These cookers must be stabilized by installing restraining chains on Noodle cookers equipped with casters or anchor straps on cookers equipped with legs. Follow the instructions shipped with the casters/legs to properly install the chains or straps.
3. Level cooker equipped with legs by extending the adjustable portion of the leg out approximately 1”, and then further adjust the legs, ensuring the cooker is level and at the proper height under the exhaust hood. For cookers equipped with casters, the floor where the cooker is to be installed must be level.
4. Refer to the data plate on the inside of the cooker door to verify that the cooker is configured for the proper type of gas before connecting the noodle cooker quick-disconnect device or piping from the gas supply line.

## CONNECT TO THE GAS LINE

The size of the gas line used for installation is very important. If the line is too small, the gas pressure at the burner manifold will be low. This may cause pilot outage, slow recovery and delayed ignition. The incoming gas supply line should be a minimum of 1½” (38 mm) in diameter. All single cookers using natural gas require a ¾” or 1/2” connection. For cookers using LP gas, one pipe size smaller may be used. If in doubt about the correct pipe size, consult the local gas company. Before connecting new pipe to your unit, the pipe must be thoroughly blown out to remove any foreign particles. If these foreign particles get into the burner and controls, they will cause improper and sometimes dangerous operation.

1. Connect the quick-disconnect hose to the noodle cooker quick-disconnect fitting at the rear of the cooker

# Installation

---

and to the building gas line.

**NOTE: some noodle cookers are configured for a rigid connection to the gas supply line. These units are connected directly to the gas supply line. When using thread compound, use very small amounts on male threads only. Use a pipe thread compound that is not affected by the chemical action of LP gases (Loctite™ PST56765 Sealant is one such compound). DO NOT apply compound to the first two threads. This will ensure that the burner orifices and control valve do not become clogged.**

2. Open the gas supply to the cooker and check all piping, fittings, and gas connections for leaks. A soap and water solution should be used for this purpose.

**NOTE: the cooker must be disconnected from the gas supply piping during any pressure testing of the gas supply piping pressures equal to or greater than ½ psig (3.45kPa or 13.84 in. W.C.).**

3. Close the cooker drain valve and fill the water tank with water or boil-out solution to the bottom WATER LEVEL line at the rear of the water tank. Light the cooker and perform the boil-out procedures that are described in the “start-up procedure” and “boiling out the water tank” topics.
4. It is suggested that the burner manifold pressure be checked at this time by the local gas company or an authorized service agent. Refer to “check burner manifold pressure” in this manual for the proper procedure.

## WATER AND GAS CONNECTION

This model is specially designed to boil pasta and noodles. Water should be connected to this unit. The black pipe is for gas connection. The middle pipe is for waste water drainage. Please make sure you have the right connection. Wrong connection would damage the valve and cause gas leakage.

# Operation

---

## OPERATING THE GAS VALVE

The knob on the gas valve is placed in the PILOT or ON position by rotating it counter-clockwise. To return the knob to the OFF position, the knob must be depressed slightly to disengage its stop tab, then rotated clockwise.

## LIGHTING THE PILOT AND BURNER

1. Open the door.
2. Turn the thermostat OFF (see figure below, view A). The thermostat is located behind the door.
3. Push the gas control valve knob and turn to OFF. Wait 5 minutes for unburned gas to vent.
4. Push and turn gas control valve knob to the “L” in PILOT (see figure below, view B).
5. While still holding the knob in, light the pilot with a lit flame. Continue to depress the knob until pilot remains lit when knob is released. If the pilot does not remain lit, repeat step 3 through 5.
6. Depress and turn gas control knob to ON (See figure below, view C).
7. If gas supply is interrupted, repeat steps 2 through 6.



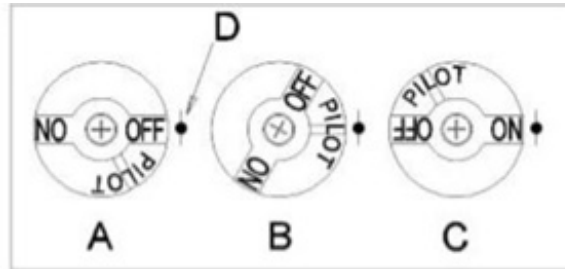

A Gas Valve Knob, View A  
B Gas Valve Knob, View B  
C Gas Valve Knob, View C  
D Indicator Point, All Views

## CAUTION

If the pilot fails to remain lit, wait five minutes before attempting to re-light.

## FILLING WITH WATER

Turn on faucet to fill the water tank with water. Do not exceed the max water-level.

## THERMOSTAT OPERATION

**Note: the boiling point of water might vary for different altitudes.**

The thermostat is connected to a graduated knob located inside the cooker door. Rotating the knob clockwise to the desired cooking temperature (set point) directly adjusts the thermostat to that temperature. The thermostat controls the water tank temperature by regulating the gas supply to the burner via the gas valve. The thermostat is in the full OFF position when the word OFF is at the top of the knob. A “click” will be heard when the knob is rotated from the OFF position to a temperature, or when it is rotated back to the OFF position.

## DRAINING

1. Rotate the gas valve knob to the PILOT or OFF position.
2. Open the drain valve slowly.
3. Clean all food particles and residual water from the water tank before refilling.
4. Close the drain valve and refill the water tank with clean water.

# Maintenance

---

## DAILY CHECKS AND SERVICES

### INSPECT COOKER AND ACCESSORIES FOR DAMAGE

Look for loose wires, leaks, foreign material in water tank or inside cabinet, and any other indications that the noodle cooker and accessories are not ready and safe for operation. Inspect the burner deflectors to verify that each is positioned directly above its orifice, and that the flame ignites approximately 2½" (60mm) above the orifice. The flame should strike the center of the deflector and be a rich blue color.

### CLEAN COOKER CABINET INSIDE AND OUT

Clean inside the cooker cabinet with dry, clean cloth. Wipe all accessible metal surfaces and components to remove accumulations dust. Clean the outside of the cooker cabinet with a clean, damp cloth soaked with dish washing detergent, removing dust, and lint from the cooker cabinet.

## QUARTERLY CHECKS AND SERVICES

### DRAIN AND CLEAN WATER TANK

During normal usage of your cooker, a deposit of Water scale will gradually form on the inside of the tank. This deposit must be periodically removed to maintain your cooker's efficiency. Follow the procedures for draining the water tank, the follow the "boiling out the water tank" procedures.

### CLEAN DETACHABLE PARTS AND ACCESSORIES

Wipe all detachable parts and accessories with a clean cloth dampened with a detergent solution. Rinse and thoroughly dry each part.

## SEMI-ANNUAL CHECKS AND SERVICE

### CHECK BURNER MANIFOLD PRESSURE

1. Ensure that the gas valve knob is in the OFF position.
2. Remove the pressure tap plug from burner manifold.
3. Insert the fitting for a manometer or pressure gauge into the pressure tap hole.
4. Place the gas valve in the PILOT position and light the pilot. When the pilot lights and continues to burn, increase the setting on the thermostat knob until the burner lights. Compare the manometer or gauge reading to the appropriate table below.
5. If the burner manifold pressure does not meet the specifications in the tables in step 4, unscrew the slotted cap from the top of the gas valve regulator (adjacent to the gas valve vent tube) and turn the adjusting screw to obtain the correct pressure. Turn the screw clockwise to increase pressure, counter-clockwise to decrease pressure.
6. After adjusting the manifold pressure to the correct value, reinstall the regulator cap and turn the gas valve knob to the OFF position.
7. Remove the manometer or pressure gauge fitting from the pressure tap hole and reinstall the pipe plug.
8. Place the gas valve in the PILOT position and check for gas leaks. If no leaks are found, re-light the pilot and return the unit to operation.

# Troubleshooting

## OPERATOR TROUBLESHOOTING

The tables that follow provide operators with a list of possible malfunctions, the probable causes of the malfunctions, and the corrective actions to take to correct the problem.

**WARNING**

!

This task should be performed by qualified service personnel only.

**WARNING**

!

The noodle/pasta cooker must be filled with water during this procedure.

In some cases the operator may not be able to correct the problem, but will at least be able to accurately diagnose the problem, and that will assist a qualified service technician in restoring the equipment to full operation in the shortest possible time.

Problem	Probable Cause	Corrective Action
Burner does not light at all.	Pilot is not lit.	Light pilot.
	Loose, dirty, or corroded terminals on gas valve.	Clean and tighten terminals on gas valve.
	Loose, dirty, or corroded terminals on thermostat.	Clean and tighten terminals on thermostat.
Burner does not light all the way around.	One or more burner orifices clogged.	Turn gas valve knob to OFF position. Use thin wire to clear obstruction from burner orifices.
	Blocked flue.	Clear blockage from flue.
Burner experiences delayed ignition.	Too little make-up air in kitchen.	Adjust kitchen ventilation system to increase make-up air.
Flame rolling out from under noodle cooker.	Flue obstructed.	Remove obstruction from flue.

# Troubleshooting

---

Pilot repeatedly goes out.	Clogged pilot orifice.	Use a small wire to clear obstruction from pilot orifice.
	Pilot flame blowing away from pilot generator (excessive draft in kitchen).	Eliminate draft in kitchen.
	Pilot generator not inserted fully into pilot burner.	Reinsert pilot generator into pilot burner until flame surrounds tip.
	Corroded connection where pilot generator connects to gas valve.	Clean pilot generator connection at gas valve.
	If all of the above causes have been ruled out. The probable causes are low pilot flame. Pilot generator low millivolt output. High resistance in hi-limit thermostat contacts, or a defective pilot magnet in the gas valve.	Call service.

# Parts Breakdown

Model CE-CN-0011-NG 47714

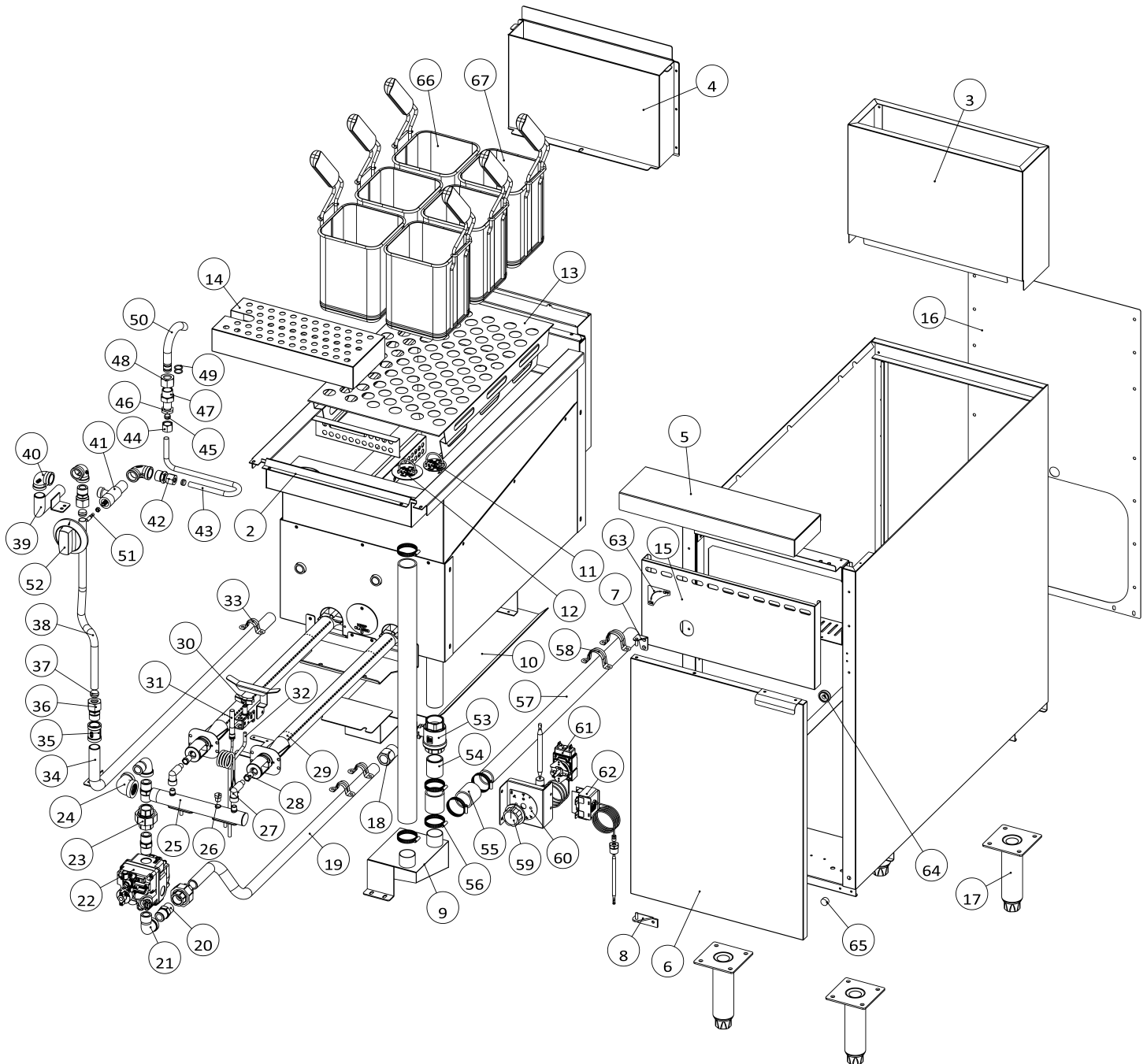

# Parts Breakdown

## Model CE-CN-0011-NG 47714

Item No.	Description	Position	Item No.	Description	Position	Item No.	Description	Position
AP112	Tank Assembly for 47714	2	AP129	1/2 to 3/4 Street Elbow for 47714	24	AP142	Faucet Nut for 47714	46
AP113	Flue Cover for 47714	3	AP130	Gas Pipe for 47714	25	AP143	Faucet Support for 47714	47
AP114	Inner Flue for 47714	4	AJ605	Test Plug for 47714	26	AP144	Water Faucet Connecting Nut for 47714	48
AP115	Front Bullnose for 47714	5	AP131	Nozzle Elbow for 47714	27	AP145	O Ring for 47714	49
AP116	Door Assembly for 47714	6	AJ595	Oven Nozzle for 47714	28	AP146	Water Pipe Welding Assembly for 47714	50
AP117	Top Door Hinge for 47714	7	AP132	Gas Burner for 47714	29	AP147	Knob Insert Shaft for 47714	51
AP118	Bottom Door Hinge for 47714	8	AN722	NG Pilot for 47714	30	AP148	Water Knob + Knob Insert for 47714	52
AP119	Overflow Box for 47714	9	AN721	Thermal Pile for 47714	31	AD733	Drain Valve for 47714	53
AP120	Heat Deflector for 47714	10	AC316	Pilot Pipe for 47714	32	AP149	Water Outlet Pipe Connector + Drain Pipe for 47714	54, 57
AP121	Drain Strainer Mesh for 47714	11	AO146	Clamp for 47714	33	AP150	Overflow Pipe for 47714	55
AP122	Overflow Strainer Mesh for 47714	12	AP133	Water Feeding Pipe for 47714	34	AP151	Pipe Clamp for 47714	56
AP123	Basket Support for 47714	13	AP134	Water Pipe Connector for 47714	35	AP152	Pipe Clamp for 47714	58
AP124	Front Strainer Plate for 47714	14	AO142	1/2 to 15 Street Elbow for 47714	36	AD722	Control Knob for 47714	59
AP125	Front Panel for 47714	15	AP135	Water Pipe Clamp for 47714	37	AP153	Bezel for 47714	60
AP126	Back Plate for 47714	16	AO143	Corrugated Pipe for 47714	38	AP154	Thermostat for 47714	61
AD718	Adjustable Leg for 47714	17	AP136	Water Pipe Assembly for 47714	39	AP155	High Limit for 47714	62
AK289	Intake Pipe Adapter for 47714	18	AP137	1/2 Street Elbow for 47714	40	AP156	Water Faucet Facial Panel for 47714	63
AP127	Gas Feeding Pipe for 47714	19	AP138	Faucet for 47714	41	AD716	Door Magnet for 47714	64
AP128	1/2 Male Thread Connector for 47714	20	AJ588	1/2-10 Pipe Connector for 47714	42	AD717	Door Column for 47714	65
AN718	Elbow for 47714	21	AP139	Flexi Pipe for 47714	43	AP157	Left Hand Basket for 47714	66
AN717	Combination Valve NG for 47714	22	AP140	Fitting Nut for 47714	44	AP158	Right Hand Basket for 47714	67
AN715	Union Connector for 47714	23	AP141	Brass Olive for 47714	45			

# Parts Breakdown

Model CE-CN-0022-NG 48000

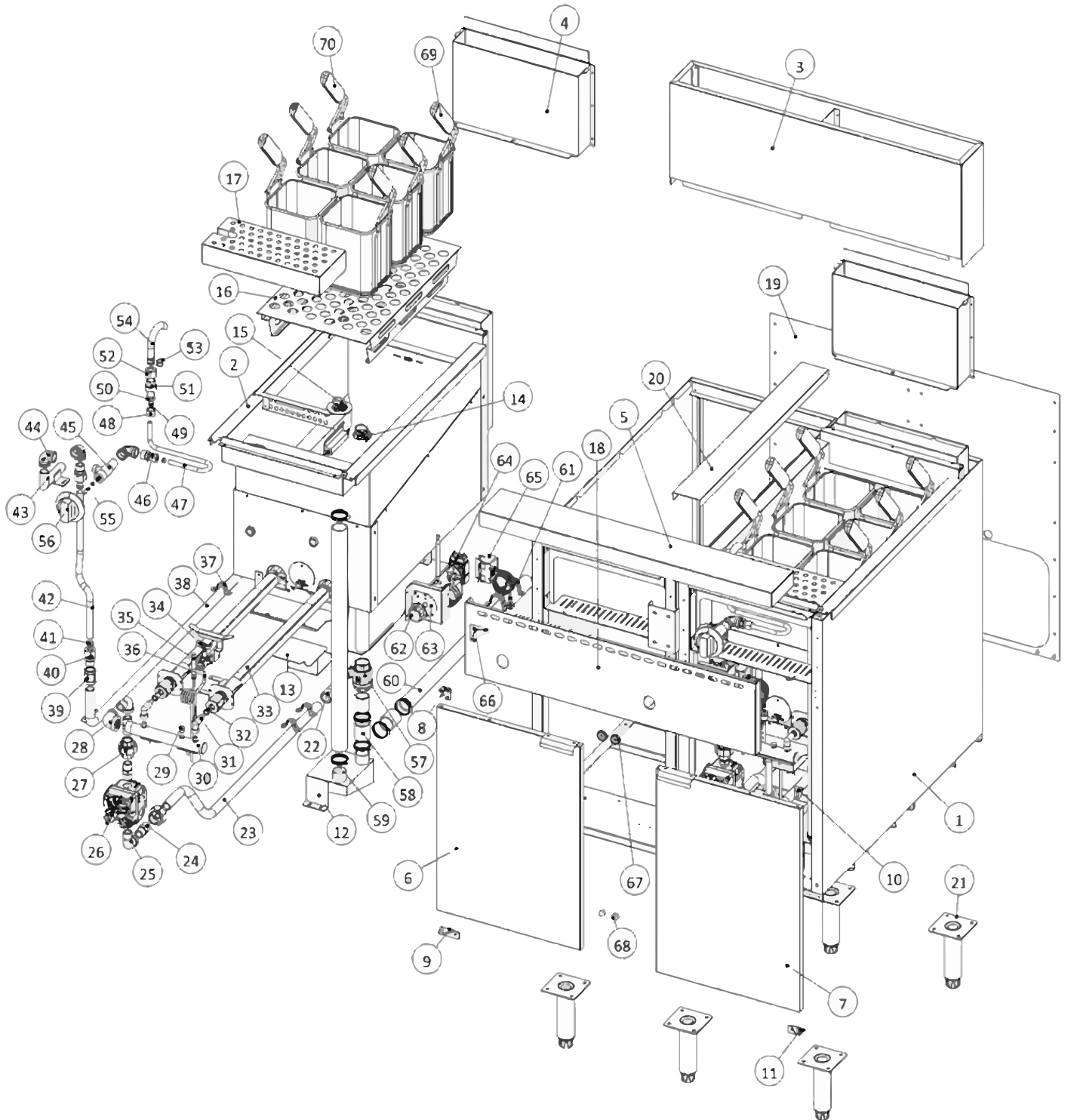

# Parts Breakdown

## Model CE-CN-0022-NG 48000

Item No.	Description	Position	Item No.	Description	Position	Item No.	Description	Position
AP492	Tank Assembly for 48000	2	AN718	Elbow for 48000	25	AP141	Brass Olive for 48000	49
AP493	Flue Cover for 48000	3	AN717	Combination Valve NG for 48000	26.1	AP142	Faucet Nut for 48000	50
AP114	Inner Flue for 48000	4	AN715	Union Connector for 48000	27, 29	AP143	Faucet Support for 48000	51
AP494	Front Bullnose for 48000	5	AP129	1/2 to 3/4 Street Elbow for 48000	28	AP144	Water Faucet Connecting Nut for 48000	52
AP495	Left Door for 48000	6	AP130	Gas Pipe for 48000	30	AP145	O Ring for 48000	53
AP496	Right Door for 48000	7	AP131	Nozzle Elbow for 48000	31	AP146	Water Pipe Welding Assembly for 48000	54
AP117	Top Door Hinge for 48000	8	AJ595	Oven Nozzle for 48000	32	AP147	Knob Insert Shaft for 48000	55
AP118	Bottom Door Hinge for 48000	9	AP132	Gas Burner for 48000	33	AP148	Water Knob+Knob Insert for 48000	56
AP497	Top Door Hinge for 48000	10	AN722	NG Pilot for 48000	34.1	AD733	Drain Valve for 48000	57
AP498	Bottom Door Hinge for 48000	11	AN721	Thermal Pile for 48000	35	AP150	Overflow Pipe for 48000	58
AP119	Overflow Box for 48000	12	AC316	Pilot Pipe for 48000	36	AP151	Pipe Clamp for 48000	59
AP120	Heat Deflector for 48000	13	AO146	Clamp for 48000	37	AP149	Water Outlet Pipe Connector+Drain Pipe for 48000	60
AP121	Drain Strainer Mesh for 48000	14	AP133	Water Feeding Pipe for 48000	38	AP152	Pipe Clamp for 48000	61
AP122	Overflow Strainer Mesh for 48000	15	AP134	Water Pipe Connector for 48000	39	AD722	Control Knob for 48000	62
AP499	Basket Support for 48000	16	AO142	1/2 to 15 Street Elbow for 48000	40	AP153	Bezel for 48000	63
AP124	Front Strainer Plate for 48000	17	AP135	Water Pipe Clamp for 48000	41	AN725	Thermostat for 48000	64
AP500	Front Panel for 48000	18	AO143	Corrugated Pipe for 48000	42	AP155	High Limit for 48000	65
AP501	Back Plate for 48000	19	AP136	Water Pipe Assembly for 48000	43	AP156	Water Faucet Facial Panel for 48000	66
AP502	Connector Strip for 48000	20	AP503	1/2 Street Elbow for 48000	44	AD716	Door Magnet for 48000	67
AD718	Adjustable Leg for 48000	21	AP138	Faucet for 48000	45	AD717	Door Column for 48000	68
AK289	Intake Pipe Adapter for 48000	22	AJ588	1/2-10 Pipe Connector for 48000	46	AP158	Right Hand Basket for 48000	69
AP127	Gas Feeding Pipe for 48000	23	AP139	Flexi Pipe for 48000	47	AP157	Left Hand Basket for 48000	70
AP128	1/2 Male Thread Connector for 48000	24	AP140	Fitting Nut for 48000	48			





# Notes

---

---

---

---

---

---

---

---

---

---

---

---

---

---

---

---

---

---

---

---

---

---

---

---

---

---



# Warranty Registration

Thank you for purchasing an Omcan product. To register your warranty for this product, complete the information below, tear off the card at the perforation and then send to the address specified below. You can also register online by visiting:

Merci d'avoir acheté un produit Omcan. Pour enregistrer votre garantie pour ce produit, complétez les informations ci-dessous, détachez la carte au niveau de la perforation, puis l'envoyer à l'adresse spécifiée ci-dessous. Vous pouvez également vous inscrire en ligne en visitant:

Gracias por comprar un producto Omcan usted. Para registrar su garantía para este producto, complete la información a continuación, cortar la tarjeta en la perforación y luego enviarlo a la dirección indicada a continuación. También puede registrarse en línea en:

<https://omcan.com/warranty-registration/>

For mailing in Canada

Pour postale au Canada

Por correo en Canadá

**OMCAN**

PRODUCT WARRANTY REGISTRATION

3115 Pepper Mill Court,  
Mississauga, Ontario  
Canada, L5L 4X5

For mailing in the US

Pour diffusion aux États-Unis

Por correo en los EE.UU.

**OMCAN**

PRODUCT WARRANTY REGISTRATION

4450 Witmer Industrial Estates, Unit 4,  
Niagara Falls, New York  
USA, 14305

*or email to: [service@omcan.com](mailto:service@omcan.com)*



Purchaser's Information

Name: \_\_\_\_\_

Address: \_\_\_\_\_

City: \_\_\_\_\_ Province or State: \_\_\_\_\_ Postal or Zip: \_\_\_\_\_

Country: \_\_\_\_\_

Dealer from which Purchased: \_\_\_\_\_

Dealer City: \_\_\_\_\_ Dealer Province or State: \_\_\_\_\_

Invoice: \_\_\_\_\_

Model Name: \_\_\_\_\_ Model Number: \_\_\_\_\_

Machine Description: \_\_\_\_\_

Date of Purchase (MM/DD/YYYY): \_\_\_\_\_

Would you like to extend the warranty?  Yes  No

Company Name: \_\_\_\_\_

Telephone: \_\_\_\_\_

Email Address: \_\_\_\_\_

Type of Company:

Restaurant  Bakery  Deli

Butcher  Supermarket  Caterer

Institution (specify): \_\_\_\_\_

Other (specify): \_\_\_\_\_

Serial Number: \_\_\_\_\_

Date of Installation (MM/DD/YYYY): \_\_\_\_\_

**Thank you for choosing Omcan | Merci d'avoir choisi Omcan | Gracias por elegir Omcan**



Since 1951 Omcan has grown to become a leading distributor of equipment and supplies to the North American food service industry. Our success over these many years can be attributed to our commitment to strengthen and develop new and existing relationships with our valued customers and manufacturers. Today with partners in North America, Europe, Asia and South America, we continually work to improve and grow the company. We strive to offer customers exceptional value through our qualified local sales and service representatives who provide convenient access to over 6,500 globally sourced products.

---

Depuis 1951 Omcan a grandi pour devenir un des “leaders” de la distribution des équipements et matériel pour l’industrie des services alimentaires en Amérique du Nord. Notre succès au cours de ces nombreuses années peut être attribué à notre engagement à renforcer et à développer de nouvelles et existantes relations avec nos clients et les fabricants de valeur. Aujourd’hui avec des partenaires en Amérique du Nord, Europe, Asie et Amérique du Sud, nous travaillons continuellement à améliorer et développer l’entreprise. Nous nous efforçons d’offrir à nos clients une valeur exceptionnelle grâce à nos ventes locales qualifiées et des représentants de service qui offrent un accès facile à plus de 6500 produits provenant du monde entier.

---

Desde 1951 Omcan ha crecido hasta convertirse en un líder en la distribución de equipos y suministros de alimentos en América del Norte industria de servicios. Nuestro éxito en estos años se puede atribuir a nuestro compromiso de fortalecer y desarrollar nuevas relaciones existentes con nuestros valiosos clientes y fabricantes. Hoy con socios de América del Norte, Europa, Asia y América del Sur, que trabajan continuamente para mejorar y crecer la empresa. Nos esforzamos por ofrecer a nuestros clientes valor excepcional a través de nuestro local de ventas y representantes de los servicios que proporcionan un fácil acceso a más de 6,500 productos con origen a nivel mundial.

